

4

3

2

1

F

F

E

E

D

D

C

C

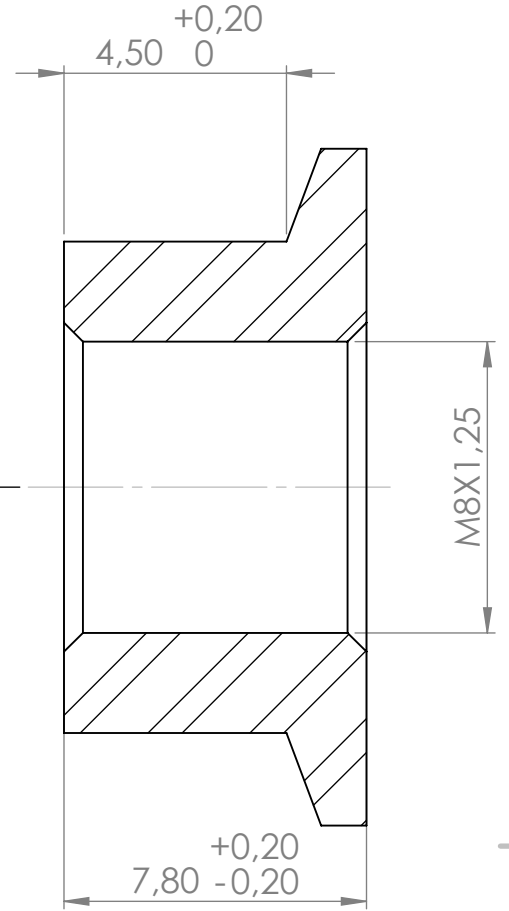
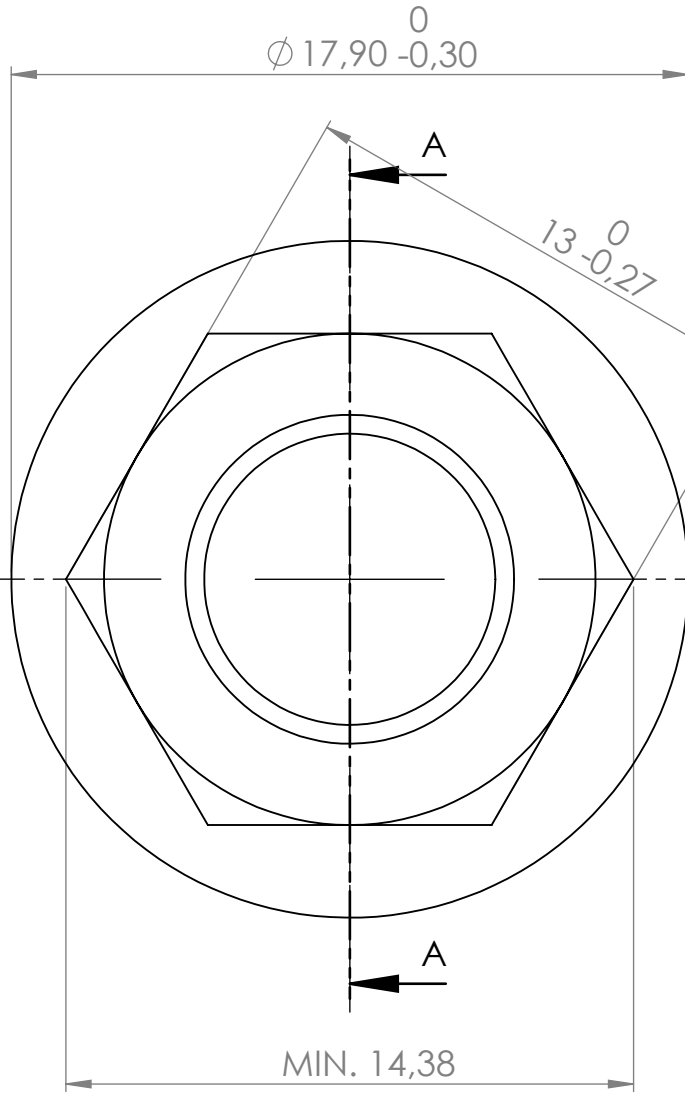

KESİT A-A  
ÖLÇEK 5 : 1

BU RESİM ENKA CİVATA'NIN İZİNİ OLMADAN ÇOĞALTILAMAZ VE KOPYALANAMAZ.  
THIS PICTURE CANNOT BE COLLECTED AND COPIED WITHOUT THE PERMISSION OF ENKA CİVATA.

	REVİZYON TARİHİ REVISION DATE	REVİZYON YAPAN REVISION PERSON	EKSTRA AÇIKLAMA EXTRA EXPLANATION		3B GÖRÜNÜM 3D VIEW			
REVİZYON NUM. REVISION NO	REV.00	24.02.2017						
REVİZYON NUM. REVISION NO								
REVİZYON NUM. REVISION NO								
	ADI / SOYADI NAME / SURNAME	GÖREV POSITION	İMZA SIGNATURE	TARİH DATE	ÇİZİM TANIMI DRAWN TITLE	M8 DIN 6923 6-8-10-12 K (QUALITY)		
ÇİZEN DRAWING	TOLGA KARANFİL	ÜRETİM SOR. PRODUCTION CHIEF		24.02.2017	ÇİZİM NUM. DRAWN NO	NDW.TD.170224007		
KONTROL CONTROL	GÜNGÖR YILDIRIM	ÜRETİM DIR. PRODUCTION DIR.		24.02.2017	ÇİZİM AÇIKLAMASI DRAWN EXPLANATION	-		
ONAY CONFIRMING	NİHAT YILDIRIM	GENEL MÜDÜR GENERAL MANAGER		24.02.2017	SAYFA TİPİ PAGE TYPE	A4	SAYFA NUM. PAGE NO	1/1
A			MALZEME MATERIAL	-	SERTLİK HARDNESS	- HRC	AĞIRLIK WEIGHT	7,55 GR
			TAVLAMA ANNEALING	-	KAPLAMA COATING	-	ŞEKİLLENDİRME FORMING	SOĞUK ŞEKİLEN. COLD FORMING

4

3

2

1

A